

Y (IP23) 系列三相异步电动机
Y (IP23) Series Three Phase Induction Motors
机座号 160~355 功 率 15~355kW
防护等级 IP23 能效等级 IE1

适用于：一般场所和无特殊要求的机械，如切削机床、泵、风机、压缩机、运输机械及其他机械设备等。

Applications: General purpose including cutting machines, pumps, fans, compressor, transportation machine and other equipments

特点：高效节能、噪声小、振动低，绝缘等级 B，外壳防护等级 IP23

Features: High efficiency and energy saving, low noise, little vibration., the insulation class is B, the protective class is IP23.

性能数据 Performance Data
380V 50HZ

型号 Type	功率 kW	额定电流 Current A	转速 r/min	效率 Eff.%	功率 因数 P.F	额定 转矩 N.m	堵转转矩 额定转矩 $\frac{T_{st}}{T_N}$	堵转电流 额定电流 $\frac{I_{st}}{I_N}$	最大转矩 额定转矩 $\frac{T_{max}}{T_N}$	噪声 dB(A)
同步转速						3000r/min				
Y160M-2	15	29	2910	88	0.88	49.2	1.7	7.0	2.2	85
Y160L1-2	18.5	36	2910	89	0.89	60.7	1.8	7.0	2.2	85
Y160L2-2	22	42	2910	89.5	0.89	72.2	2.0	7.0	2.2	85
Y180M-2	30	57	2940	89.5	0.89	97.4	1.7	7.0	2.2	88
Y180L-2	37	70	2940	90.5	0.89	120	1.9	7.0	2.2	88
Y200M-2	45	84	2940	91	0.89	146	1.9	7.0	2.2	90

Mob.: +86-13931192007 Tel: +86-311-89246924
Web: www.zcl-group.com Email : zclgroup@zcl-group.com
Factory Add: Zhangjiazhuang Town Motor Industrial Park Gaocheng District Shijiazhuang Hebei China

Y200L-2	55	103	2950	91.5	0.89	178	1.9	7.0	2.2	90
Y225M-2	75	140	2960	91.5	0.89	242	1.8	7.0	2.2	92
Y250S-2	90	167	2960	92	0.89	290	1.7	7.0	2.2	97
Y250M-2	110	201	2960	92.5	0.90	355	1.7	7.0	2.2	97
Y280M-2	132	241	2970	92.5	0.90	424	1.6	7.0	2.2	99
Y315S-2	160	290	2970	92.5	0.90	514	1.4	6.8	2.0	105
Y315M1-2	185	338	2970	92.5	0.90	595	1.4	6.8	2.0	105
Y315M2-2	200	363	2970	93.0	0.90	643	1.4	6.8	2.0	105
Y315M3-2	220	397	2975	93.5	0.90	706	1.4	6.8	2.0	105
Y315M4-2	250	460	2975	93.8	0.88	803	1.2	6.8	2.0	107
Y355M2-2	280	514	2975	94.0	0.88	899	1.0	6.5	1.8	107
Y355M3-2	315	572	2975	94.0	0.89	1011	1.0	6.5	1.8	107
Y355L1-2	355	643	2975	94.3	0.89	1140	1.0	6.5	1.8	107

性能数据 Performance Data
380V 50HZ

型号 Type	功率 kW	额定电流 Current t A	转速 r/min	效率 Eff.%	功率 因数 P.F	额定 转矩 N.m	堵转转矩 额定转矩 $\frac{T_{st}}{T_N}$	堵转电流 额定电流 $\frac{I_{st}}{I_N}$	最大转矩 额定转矩 $\frac{T_{max}}{T_N}$	噪声 dB(A)
同步转速 1000r/min										
Y280S-6	75	143	980	91.5	0.87	731	1.8	6.5	2.0	90
Y280M-6	90	169	980	92.0	0.88	877	1.8	6.5	2.0	90
Y315S-6	110	207	980	93.0	0.87	1072	1.3	6.5	1.8	97
Y315M1-6	132	247	980	93.5	0.87	1286	1.3	6.5	1.8	100
Y315M2-6	160	298	980	93.8	0.87	1559	1.3	6.5	1.8	100
Y355M1-6	185	344	980	94.0	0.87	1803	1.1	6.0	1.8	100
Y355M2-6	200	372	980	94.0	0.87	1949	1.1	6.0	1.8	100
Y355M3-6	220	404	985	94.0	0.88	2133	1.1	6.0	1.8	100
Y355M4-6	250	458	985	94.3	0.88	2424	1.1	6.0	1.8	103

Mob.: +86-13931192007 Tel: +86-311-89246924
Web: www.zcl-group.com Email : zclgroup@zcl-group.com
Factory Add: Zhangjiazhuang Town Motor Industrial Park Gaocheng District Shijiazhuang Hebei China

Y355L1-6	280	513	985	94.3	0.88	2715	1.1	6.0	1.8	103
Y400-1-6	315	586	990	93.7	0.83	3039	1.9	7.0	2.3	
Y400-2-6	355	660	990	93.9	0.83	3424	1.9	7.0	2.3	
Y400-3-6	400	740	990	94.0	0.83	3859	1.9	7.0	2.3	
Y400-4-6	450	832	990	94.3	0.84	4341	1.9	7.0	2.3	
Y400-5-6	500	924	990	94.5	0.84	4823	1.6	7.0	2.3	
同步转速 750r/min										
Y160M-8	5.5	14	720	83.5	0.73	73.0	2.0	6.0	2.0	72
Y160L-8	7.5	18	720	85	0.73	99.5	2.0	6.0	2.0	75
Y180M-8	11	26	720	86.5	0.74	146	1.8	6.0	2.0	75
Y180L-8	15	34	720	87.5	0.76	199	1.8	6.0	2.0	83
Y200M-8	18.5	41	730	88.5	0.78	242	1.7	6.0	2.0	83
Y200L-8	22	48	740	89.0	0.78	284	1.8	6.0	2.0	83
Y225M-8	30	63	740	89.5	0.81	387	1.7	6.0	2.0	86
Y250S-8	37	78	740	90.0	0.80	478	1.6	6.0	2.0	86
Y250M-8	45	94	740	90.5	0.80	581	1.8	6.0	2.0	88
Y280S-8	55	115	740	91.0	0.80	710	1.8	6.0	2.0	88
Y280M-8	75	154	740	91.5	0.81	968	1.8	6.0	2.0	91
Y315S-8	90	183	740	92.2	0.81	1161	1.3	6.0	1.8	93
Y315M1-8	110	222	740	92.8	0.81	1420	1.3	6.0	1.8	93
Y315M2-8	132	265	740	93.3	0.81	1704	1.3	6.0	1.8	97
Y355M2-8	160	321	740	93.5	0.81	2065	1.1	5.5	1.8	97
Y355M3-8	185	371	740	93.5	0.81	2388	1.1	5.5	1.8	97
Y355M4-8	200	401	740	93.5	0.81	2581	1.1	5.5	1.8	97
Y355L1-8	220	439	740	94.0	0.81	2839	1.1	5.5	1.8	97
Y355L2-8	250	512	740	94.0	0.79	3226	1.1	5.5	1.8	99

Mob.: +86-13931192007 Tel: +86-311-89246924

Web: www.zcl-group.com Email : zclgroup@zcl-group.com

Factory Add: Zhangjiazhuang Town Motor Industrial Park Gaocheng District Shijiazhuang Hebei China

性能数据 Performance Data
380V 50HZ

型号 Type	功率 kW	额定电流 Current A	转速 r/min	效率 Eff.%	功率 因数 P.F	额定 转矩 N.m	堵转转矩 额定转矩 $\frac{T_{st}}{T_N}$	堵转电流 额定电流 $\frac{I_{st}}{I_N}$	最大转矩 额定转矩 $\frac{T_{max}}{T_N}$	噪声 dB(A)
同步转速						750r/min				
Y400-1-8	250	490	740	93.0	0.79	3226	1.8	6.8	2.0	
Y400-2-8	280	548	740	93.2	0.79	3614	1.8	6.8	2.3	
Y400-3-8	315	613	740	93.4	0.8	4065	1.8	6.8	2.3	
同步转速						600r/min				
Y315S-10	55	123	590	91.5	0.74	890	1.2	5.5	1.8	93
Y315M1-10	75	165	590	92.0	0.75	1214	1.2	5.5	1.8	93
Y315M2-10	90	196	590	92.0	0.76	1457	1.2	5.5	1.8	93
Y355M2-10	110	232	590	92.5	0.78	1781	1.0	5.5	1.8	93
Y355M3-10	132	274	590	92.8	0.79	2137	1.0	5.5	1.8	97
Y355L1-10	160	332	590	92.8	0.79	2590	1.0	5.5	1.8	97
Y355L2-10	185	383	590	93.0	0.79	2994	1.0	5.5	1.8	97
Y400-1-10	200	427	590	92.0	0.77	3237	1.6	6.0	1.8	
Y400-2-10	220	469	590	92.1	0.77	3561	1.6	6.0	1.9	
Y400-3-10	250	533	590	92.3	0.78	4047	1.6	6.0	1.9	
Y400-4-10	280	597	590	92.5	0.78	4532	1.6	6.0	1.9	
Y400-5-10	315	663	590	92.6	0.79	5099	1.6	6.5	1.9	
同步转速						500r/min				
Y355M4-12	90	201	475	92.0	0.74	1809	1.0	5.5	1.8	93
Y355L1-12	110	241	475	92.3	0.75	2212	1.0	5.5	1.8	93
Y355L2-12	132	289	475	92.5	0.75	2654	1.0	5.5	1.8	97

Mob.: +86-13931192007 Tel: +86-311-89246924
Web: www.zcl-group.com Email: zclgroup@zcl-group.com
Factory Add: Zhangjiazuang Town Motor Industrial Park Gaocheng District Shijiazhuang Hebei China

外形及安装尺寸

Dimensions

mm

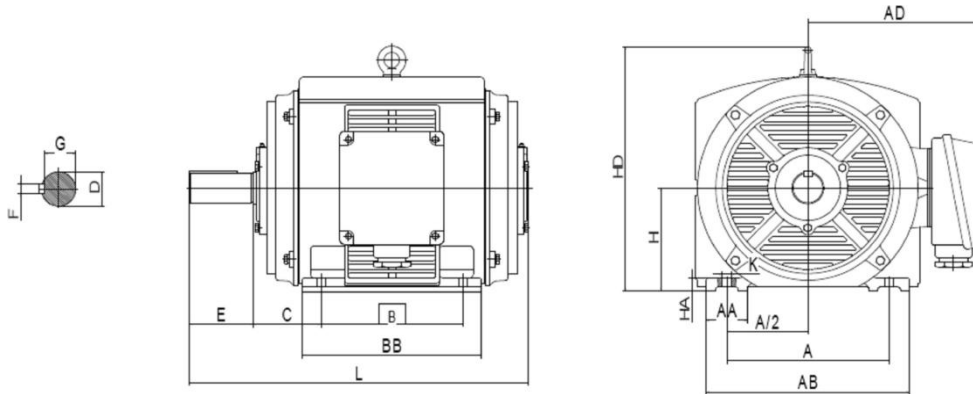

机座号 Frame	极数 Poles	安装尺寸 Mounting Dimension									外形尺寸 Overall Dimension				
		A	B	C	D	E	F	G	H	K	AB	AC	AD	HD	L
160M	2.4.6.8	254	210	108	48	110	14	42.5	160	14.5	330	380	290	440	676
160L	2.4.6.8	254	254	108	48	110	14	42.5	160	14.5	330	380	290	440	676
180M	2.4.6.8	279	241	121	55	110	16	49	180	14.5	350	420	325	505	726
180L	2.4.6.8	279	279	121	55	110	16	49	180	14.5	350	420	325	505	726
200M	2.4.6.8	318	267	133	60	140	18	53	200	18.5	400	465	350	570	820
200L	2.4.6.8	318	305	133	60	140	18	53	200	18.5	400	465	350	570	886
225M	2	356	311	149	60	140	18	53	225	18.5	450	520	395	640	880
225M	4.6.8	356	311	149	65	140	18	58	225	18.5	450	520	395	640	880
250S	2	406	311	168	65	140	18	58	250	18.5	510	550	410	710	930
250S	4.6.8	406	311	168	75	140	20	67.5	250	24	510	550	410	710	930
250M	2	406	349	168	65	140	18	58	250	24	510	550	410	710	960
250M	4.6.8	406	349	168	75	140	20	67.5	250	24	510	550	410	710	960
280S	4.6.8	457	368	190	80	170	22	71	280	24	570	610	485	785	1090
280M	2	457	419	190	65	140	18	58	280	24	570	610	485	785	1090
280M	4.6.8	457	419	190	80	170	22	71	280	24	570	610	485	785	1140
315S	2	508	406	216	70	140	20	62.5	315	28	630	729	586	928	1130
315S	4.6.8.10	508	406	216	90	170	25	81	315	28	630	729	586	928	1160
315M	2	508	457	216	70	140	20	62.5	315	28	630	729	586	928	1240
315M	4.6.8.10	508	457	216	90	170	25	81	315	28	630	729	586	928	1270

Mob.: +86-13931192007 Tel: +86-311-89246924

 Web: www.zcl-group.com Email: zclgroup@zcl-group.com

Factory Add: Zhangjiazhuang Town Motor Industrial Park Gaocheng District Shijiazhuang Hebei China



ZCL Electric Motor Technology Co., Ltd.

355M	2	610	560	254	75	140	20	67.5	355	28	710	980	930	1120	1550
355M	4.6.8.10	610	560	254	100	210	28	90	355	28	710	980	930	1120	1620
355L	2	610	630	254	75	140	20	67.5	355	28	710	980	930	1120	1620
355L	4.6.8.10	610	630	254	100	210	28	90	355	28	710	980	930	1120	1690

Mob.: +86-13931192007 Tel: +86-311-89246924

Web: www.zcl-group.com Email : zclgroup@zcl-group.com

Factory Add: Zhangjiazhuang Town Motor Industrial Park Gaocheng District Shijiazhuang Hebei China